

# Magnetron Theory of Operation

## Communications & Power Industries Magnetron Theory of Operation

A magnetron is a high power microwave oscillator in which the potential energy of an electron cloud near the cathode is converted into r.f. energy in a series of cavity resonators similar to the one shown in Figure 1. As depicted by the low frequency analog, the rear wall of the structure may be considered the inductive portion, and the vane tip region the capacitor portion of the equivalent resonant circuit. The resonant frequency of a microwave cavity is thereby determined by the physical dimension of the resonator together with the reactive effect of any perturbations to the inductive or capacitive portion of the equivalent circuit. This is an important point and will be recalled later.

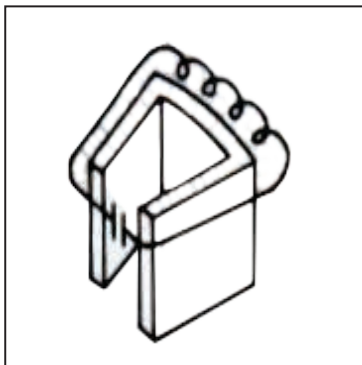

**Figure 1**  
Magnetron  
Resonator

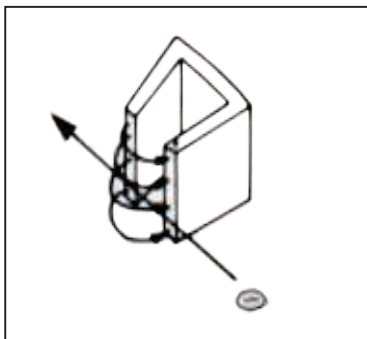

**Figure 2**  
Energy  
Transfer  
Mechanism

In order to sustain oscillations in a resonant circuit, it is necessary to continuously input energy in the correct phase. Referring to Figure 2, if the instantaneous r.f. field, due to steady state oscillations in the resonator, is in the direction shown, and, an electron with velocity was to travel through the r.f. field such that the r.f. field retarded the electron velocity by an amount, the decrease in electron energy will be exactly offset by an increase in the r.f. field strength.

In a magnetron, the source of electrons is a heated cathode located on the axis of an anode structure containing a number of microwave resonators. See Figure 3.

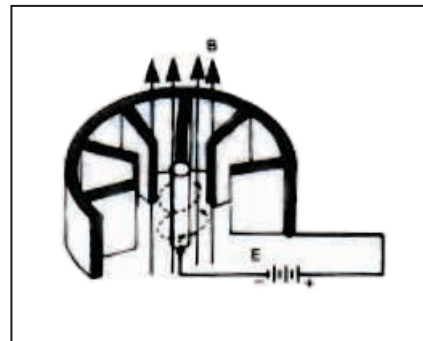

**Figure 3**  
Anode/  
Cathode  
Structure

Electrons leave the cathode and are accelerated toward the anode, due to the dc field established by the voltage source E. The presence of a strong magnetic field B in the region between cathode and anode produces a force on each electron which is mutually perpendicular to the dc field and the electron velocity vectors, thereby causing the electrons to spiral away from the cathode in paths of varying curvature, depending upon the initial electron velocity at the time it leaves the cathode.

# Magnetron Theory of Operation pg. 2

As this cloud of electrons approaches the anode, it falls under the influence of the RF fields at the vane tips, and electrons will either be retarded in velocity, if they happen to face an opposing r.f. field, or accelerated if they are in the vicinity of an aiding r.f. field. Since the force on an electron due to the magnetic field  $B$  is proportional to the electron velocity through the field, the retarded velocity electrons will experience less "curling force" and will therefore drift toward the anode, while the accelerated velocity electrons will curl back away from the anode.

The result is an automatic collection of electron "spokes" as the cloud nears the anode (see Figure 4), with each spoke located at a resonator having an opposing RF field. On the next half cycle of r.f. oscillation, the RF field pattern will have reversed polarity and the spoke pattern will rotate to maintain its presence in an opposing field.

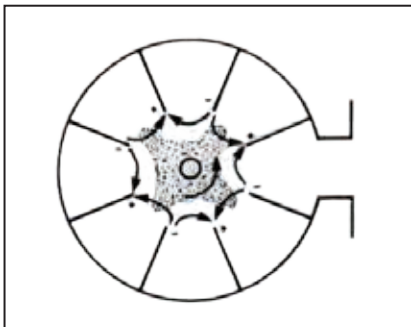

**Figure 4**  
**Electron**  
**spokes in a**  
**magnetron**

The "automatic" synchronism between the electron spoke pattern and the RF field polarity in a crossed field device allows a magnetron to maintain relatively stable operation over a wide range of applied input parameters. For example, a magnetron designed for an output power of 200 kW peak will operate quite well at 100 kW peak output by simply reducing the modulator drive level.

You will note that the instantaneous RF field pattern, shown in Figure 4, has exactly  $180^\circ$  of phase

change (radians) between every adjacent pair of resonator vanes and is therefore called the mode. Other oscillation patterns (modes) could be supported by the anode structure; however, the mode pattern will produce the maximum number of electron spokes, and therefore the maximum transfer of energy to the RF field, i.e., highest efficiency mode. Assuring that the magnetron maintains mode oscillation, to the exclusion of all other modes, is one of the prime concerns of the magnetron designer.

The mode controlling techniques in a conventional magnetron, e.g., electrically connecting alternate vane tips together to assure identical potential, employing geometrical similarities between alternate resonators to favor mode oscillation, will adequately maintain mode control in conventional magnetron anodes. Due to mode separation parameters, the number of resonators in conventional magnetron anodes is limited and rarely exceeds 20 resonator vanes. Since the physical size of each resonator is fixed by the desired output frequency, the overall size of the anode is limited, thereby restricting cathode dimensions and heat dissipation capacity. The result is that at higher frequencies the conventional magnetron has reduced power output capability, lower reliability and a shorter operating lifetime than can be realized at the lower microwave frequencies.

The distinguishing feature of the coaxial magnetron is the presence of a high  $Q$  stabilizing cavity between the anode and the output waveguide.

The theory of operation presented for a conventional magnetron applies equally to the anode-cathode region of the coaxial structure. However, the coaxial stabilizing cavity affords very significant improvements in overall magnetron performance.

# Magnetron Theory of Operation pg. 3

**Superior mode control:** Operating the cavity in the TE<sub>011</sub> mode, and slot coupling alternate anode resonators to the cavity, produces anode control of such intensity as to permit the construction of coaxial magnetrons with many times the number of resonators that can be employed in a conventional type magnetron. This means lower cathode emission density, lower life and higher reliability.

**Reduced RF fields in the anode:** Whereas all stored energy in a conventional is confined to the vane resonators, in a coaxial magnetron approximately 85% of the total stored energy is contained in the stabilizing cavity. This means reduced RF field intensity at the vane tips, and less tendency to arcing.

**Improved frequency stability:** The redistribution of stored energy in the coaxial magnetron makes the high Q stabilizing cavity the prime determiner of magnetron output frequency. This means a lower pushing figure, a lower pulling figure, improved spectrum and reduced spurious emissions.

**Improved tuning:** In the conventional magnetron, tuning is accomplished by inserting inductive pins in the rear portion of each resonator, or by capacitive loading in the vane tip region.

Both techniques represent an adverse perturbation to the natural geometry of the resonators which often results in power output variation with tuning, starting instabilities, increased susceptibility to arcing and a generally reduced operating lifetime for the magnetron. In contrast the coaxial magnetron is tuned by moving a noncontacting plunger in the stabilizing cavity (see Figure 5). The result is a tuning characteristic with no discontinuities, broad tunable bandwidth, and none of the disadvantages resulting from perturbations in the anode-cathode region.

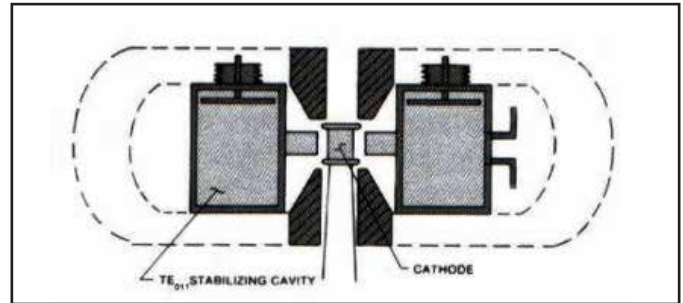

Figure 5: Coaxial Magnetron

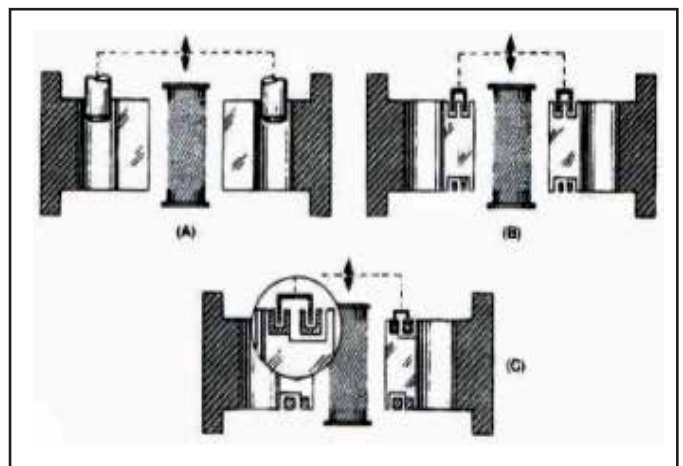

Figure 6: Three types of tuning schemes used in conventional magnetron resonator systems

## Typical Magnetron Parameters

The following is a discussion and explanation of typical magnetron specification parameters.

### Thermal Drift

At the time high voltage is first applied to a magnetron, the thermal equilibrium of the device is suddenly altered. The anode vanes being to heat at the tips due to electron bombardment and the entire anode/cathode structure undergoes a transient

# Magnetron Theory of Operation pg. 4

change in thermal profile. During the time required for each part of the magnetron to stabilize at its normal operating temperature, the output frequency of the magnetron will "drift." The curve of output frequency vs. time during the period following initial turn on is called the "Thermal Drift" curve. Generally speaking, the maximum drift occurs during the first few minutes after turn on, and slowly approaches equilibrium over a period ranging from 10 to 30 minutes depending upon the structure mass, power output, type of cooling and basic magnetron design. Thermal drift curves across a variety of magnetron types operating at the same frequency and output power may differ radically from each other. Each type is usually designed for a particular purpose and subtle differences in the internal magnetron configuration can produce radical differences in the thermal drift curve.

It should be noted that a thermal drift effect will occur not only at initial turn-on, but whenever the peak or average input power to the magnetron is changed, e.g., a change of pulse duration, PRF or duty. Figure 7 shows typical thermal drift curves for a particular magnetron plotted as a function of duty. The dotted line indicates the effect of a change in duty from .001 to .0005 after thermal equilibrium has been initially achieved.

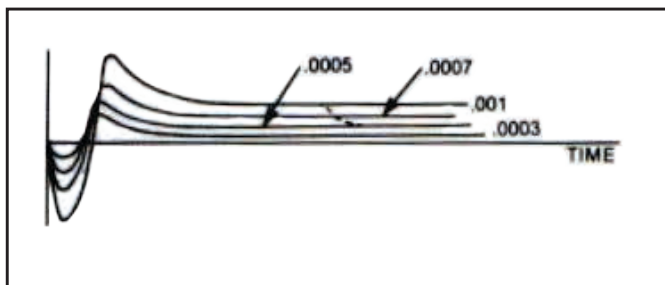

Figure 7: Typical thermal drift curves

## Temperature Coefficient

After the thermal drift period has expired and a stable operating frequency has been achieved, changes to ambient conditions which cause a corresponding change in the magnetron temperature will produce a change in the output frequency. In this content ambient changes include cooling air temperature or pressure in air cooled magnetrons; mounting plate temperature in heat sink cooled magnetrons; and flow rate or temperature in liquid cooled magnetrons.

The change in magnetron output frequency for each degree change in body temperature, as measured at a specified point on the outside surface of the magnetron body, is defined as the Temperature Coefficient for the magnetron and is usually expressed in MHz/oC. For most magnetrons the temperature coefficient is a negative (frequency decreases as temperature increases) and is essentially constant over the operating range of the magnetron.

When estimating magnetron frequency change due to temperature coefficient, keep in mind that the temperature coefficient relates magnetron frequency to body temperature and there is not necessarily a 1:1 relation between body temperature and, for example, ambient air temperature. In addition, for airborne systems, the cooling effect of lower air temperature at altitude may offset by a corresponding reduction in air density.

## Pushing Figure

The pushing figure of a magnetron is defined as the change in magnetron frequency due to a change in the peak cathode current. Referring back to the earlier theory discussion, we noted that the

# Magnetron Theory of Operation pg. 5

the resonant frequency of a vane resonator is determined by its mechanical dimensions plus the reactive effect of any perturbation. The presence of electrons in the vicinity of the vane tips affects the equivalent capacitance of the resonator by an amount proportional to the density of the electrons and, since electron density is similarly related to peak pulse current, changes in pulse current level will produce changes in output frequency. The pushing figure expressed in MHz/Amp is represented by the slope of a frequency vs. peak current curve plotted for a particular magnetron type.

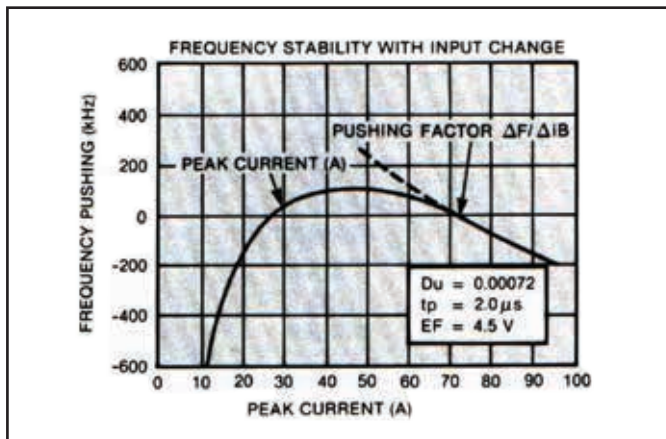

Figure 8: Typical thermal pushing curve

From the curve of Figure 8, it can be seen that the slope is not a constant over the full range of operating current. It is therefore meaningless to talk about a specific value for the pushing figure unless one also specifies the range of peak current over which it applies.

It should be noted that since power output is proportional to peak current in a magnetron, the pushing figure at peak current levels well below the normal operating point of the magnetron are usually unimportant because the power output at these current levels is low.

The primary importance of a low pushing figure near the magnetron operating point is that the pushing figure will determine intrapulse FM, and thereby will affect the spectral quality of the transmitting pulse.

The Pulling Figure is defined as the maximum change in output frequency that results when an external, fixed amplitude mismatch, located in the output waveguide, is moved through a distance of one half wavelength relative to the magnetron. Stated somewhat less formally, the pulling figure is a measure of a magnetron's ability to maintain a constant output frequency against changes in load mismatch.

During the design of a magnetron, the degree to which the output waveguide is electrically coupled to the internal resonator structure is selected to optimize certain performance parameters. Strong coupling increases output power and efficiency but also increases time jitter and sensitivity to changes to load mismatch. Generally, the coupling is chosen to obtain the best compromise between efficiency and stability.

Depending upon the phase relation between incident and reflected power at the output port of a magnetron, reflected power will appear as a reactance across the coupling transformer and effectively change the degree of coupling. Therefore, using a fixed mismatch and varying its distance from the magnetron output port will cause the magnetron frequency to shift and the output power to vary concurrently.

To standardize the measurement values, pulling figure is normally measured using a fixed 1.5:1 VSWR; however, in very high power magnetrons a 1.3:1 VSWR is often used. When referring to the pulling figure of a magnetron one should always indicate the VSWR value used in the measurement.

## Magnetron Theory of Operation: Frequency Agile Magnetrons

Frequency agility (FA) in regard to radar operations, is defined as the capability to tune the output frequency of the radar with sufficient speed to produce a pulse-to-pulse frequency change greater than the amount required to effectively obtain decorrelation of adjacent radar echoes.

It has been firmly established that FA, together with appropriate receiver integration circuits, affords reduced target scintillation/glint, improved ability to detect targets in a clutter environment, elimination of 2nd time around echoes, and improved resistance to electronic countermeasures, over that possible with a fixed frequency or tunable radar system. It is important to note that, with the exception of ECM resistance, increasing the pulse-to-pulse frequency spacing will increase the amount of system performance improvement that can be realized to a maximum occurring at the point where full pulse echo decorrelation is obtained (nominally 1/tp). Pulse-to-pulse frequency spacings greater than this critical value produce no further increase in system performance, and, in fact, may result in a performance decrease due to the large "IF" inaccuracies arising from the need for the AFC to correct larger pulse to pulse frequency errors.

On the other hand, as regards resistance to electronic jamming (ECCM), the greater the pulse-to-pulse frequency spacing, the more difficult it will be to center a jamming transmitter on the radar frequency to effectively interfere with system operation.

Each radar system application must be considered separately to determine which FA parameters will best satisfy the particular need. Just as the FA requirements of each radar differ, so also do the mechanisms differ for optimally producing the required agility parameters. No single tuning scheme has been found which will universally satisfy the requirements of every FA application.

For this reason, CPI produces a broad range of FA tuning mechanisms for coaxial magnetrons; each

mechanism offering the optimum combination of parameters for a particular application.

### Frequency Agile Magnetron Classes

Frequency agile magnetrons fall into four classes:

- **Dither Magnetrons (D)** -- Output RF frequency varies periodically with a constant excursion, constant rate and a fixed-center frequency.
- **Tunable/Dither Magnetrons (T/D)** -- Output RF frequency varies periodically with a constant excursion and constant rate. The center frequency may be slowly tuned by hand or by external servomotor drive to any point within the tunable band.
- **Accutune(tm) Magnetrons (A)** -- Output RF frequency variations are determined by the waveshape of an externally generated, low level, voltage signal. With appropriate selection of a tuning waveshape, the Accutune magnetron combines the features of dither and tunable/dither magnetrons.
- **Accusweep(tm) Magnetrons (As)** -- Our best and most versatile tuning system. The output RF tuning rate and waveshape are infinitely variable within the design limits of each device. Customer inputs are typically any waveform from random to square wave and a + 5 volt command.

All CPI frequency-agile magnetrons provide a reference voltage output which is an accurate analog of the instantaneous RF output frequency. This signal greatly simplifies automatic frequency control of the system local oscillator frequency. The analog voltage is produced either by a self-generating, permanent magnet device requiring no external drive, or by a precision resolve or LVDT (Linear Voltage Displacement Transducer) acting in conjunction with one of CPI's solid-state frequency readout modules.

The Accutune and Accusweep magnetrons operate with a servo loop, feedback control, tuner drive and thereby utilize CPI's solid-state servo amplifier together with the frequency readout module.

## Magnetron Theory of Operation: Frequency Agile Magnetrons

permanent magnet device requiring no external drive, or by a precision resolve or LVDT (Linear Voltage Displacement Transducer) acting in conjunction with one of CPI's solid-state frequency readout modules.

The Accutune and Accusweep magnetrons operate with a servo loop, feedback control, tuner drive and thereby utilize CPI's solid-state servo amplifier together with the frequency readout module.

### Agile Magnetron Design Considerations

At first glance one might conclude that the largest frequency change at the highest rate will give the best radar performance. Unfortunately, this is not a true statement.

There have been many separate theoretical studies and comprehensive experiments performed to establish the relationship between radar performance improvement and pulse-to-pulse frequency difference. An understanding of the theoretical basis for the conclusions reached in these efforts is important. In order to preserve the continuity of our discussion, we will show only the results of these studies in this section.

Effective performance improvement is achieved when the frequency difference between radar pulses is large enough to eliminate any correlation between the return echoes. A plot of correlation coefficient versus pulse to pulse frequency difference is shown below.

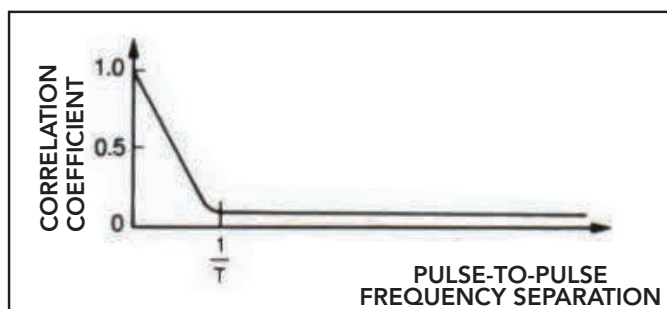

Using this relationship, one finds that a radar operating at a 0.5  $\mu$ s pulse duration will have efficient decorrelation between target echoes if pulses differ in frequency by at least 2 MHz. Note that the required frequency separation is a function only of the pulse duration.

According to the plot of the figure, as frequency separation increases above the value  $1/T$ , pulse decorrelation continues to improve, however, the amount of improvement is negligibly small for large increases in pulse frequency separation. In practical situations, the improvement in decorrelation obtained by increasing the frequency separation to values greater than  $1/T$  is usually more than offset by other factors. For example, as pulse-to-pulse frequency difference increases, the receiver circuitry needed to assure stable LO (Local Oscillator) tracking also increases, in both complexity and physical size. The accuracy necessary for LO tracking relates directly to the IF bandwidth needed to pass the resultant video signal. Any increase in IF bandwidth, needed to offset inaccuracies in LO tracking, will reduce overall receiver sensitivity and tend to defeat the original purpose. Experience has shown that if one designs for pulse-to-pulse frequency separation as near as possible to, but not less than,  $1/T$  (where  $T$  is the shortest pulse duration used in the radar) optimum system performance will be achieved. Experimental studies have shown that performance improvement varies as  $N$ , where  $N$  is the number of independent (decorrelated) pulses integrated within the receiver circuitry, up to a maximum of 20 pulses.

It should be noted that the number of pulses, which can be effectively integrated, cannot be greater than the number of pulses placed on the target during one scan of the antenna and, therefore, the antenna beamwidth and scan rate become factors which must also be considered in determining the integration period of the radar.

# Magnetron Theory of Operation pg. 8

## Magnetron Theory of Operation: Frequency Agile Magnetrons

Using the above, a design value for Agile Excursion can now be expressed in terms of radar operating parameters.

$$\text{Agile Excursion} = N/T$$

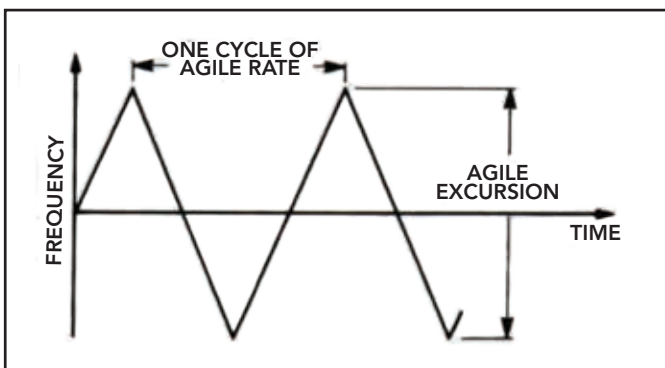

**Agile Excursion:** The total frequency variation of the transmitter during agile operation.

**Agile Rate:** The number of times per second that the transmitter frequency traverses the agile excursion and returns to its starting frequency.

NOTE: There are two excursions of the frequency band for each cycle of agile rate.

Where N is the number of pulses placed on the target during one radar scan, or 20 whichever is smaller, and T is the shortest pulse duration used in the system.

Determination of the required agile rate is now required. The object is to traverse the full agile excursion range in the time needed to transmit the number of pulses on the target during one antenna scan.

### Example:

Assume one desires to add agility to a radar having the following operating parameters:

**Pulse duration - 0.25, 0.5 & 1.0  $\mu$ Sec.**

**Duty Ratio - 0.001**

**Pulses on target - 16 per scan**

Using the formulas derived above one obtains:

**Agile excursion =  $N/T = 16/0.25 = 64$  MHz**

**Pulse to pulse frequency separation =  $1/T = 1/0.25 = 4$  MHz**

**PRR = Duty / T =  $0.001 / (0.25 \times 10^{-6}) = 4000$  Hz**

**Time for 16 pulses =  $16 / 4000 = 0.004$  Sec**

**Agile Rate\* =  $1/(2 \times 0.004) = 125$  Hz**

\* The 2 in the denominator accounts for the fact that two excursions through the agile frequency range occur during each cycle of agile rate.

The agile parameters used above were derived using clutter reduction as the prime objective. Elimination of target scintillation requires the satisfaction of one additional constraint, namely that the agile excursion in MHz should be at least equal to  $150/D$ , where D is the characteristic distance, in meters, between major reflecting points on the target cross section. For most practical situations, an excursion which satisfied the requirements of clutter reduction will usually be sufficient to satisfy the requirements of target scintillation also.

Further information and data on agile coaxial magnetrons can be obtained by requesting the Frequency Agile Magnetron Story booklet.



## Magnetron Theory of Operation: Beacon Magnetrons

Beacon magnetrons are small conventional magnetrons with peak power output less than 4 kW and average power output of less than 5 watts. Typically, they weigh 8 ounces.

The technical requirements for this class of magnetrons demand precise frequency control of the magnetron. The temperature stability factor is of great importance since it allows frequency control without additional electronics in the total radar transponder. The magnetron itself requires tunability but must have the properties of a fixed frequency magnetron after adjustment and locking. Thus, the techniques of temperature compensation must work over a band of frequencies. Also, frequency stability is essential over typical temperature ranges of -65°C to +100°C, and typical shock of 100 G, and vibration environments of 15 G (generally those of missile and aircraft electronic systems). Construction of beacon magnetrons can be simplified to contain five basic building blocks. They are the anode, tuner, cathode, output, and magnet. These may be arranged in block diagram fashion as shown in Figure 1.

The following sections will discuss each of the five parts of the magnetron.

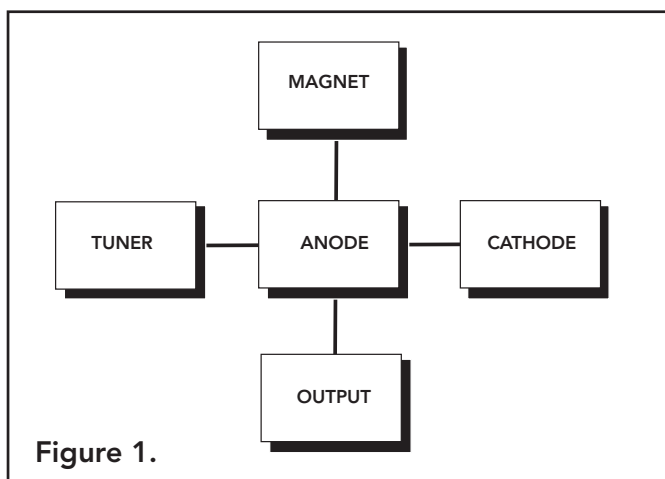

### Anode

The anode is the foundation of the magnetron circuit. It generally consists of an even number of microwave cavities arranged in radial fashion as shown. There are three possible anode configurations:

- Hole and slot
- Vane tip
- Rising sun

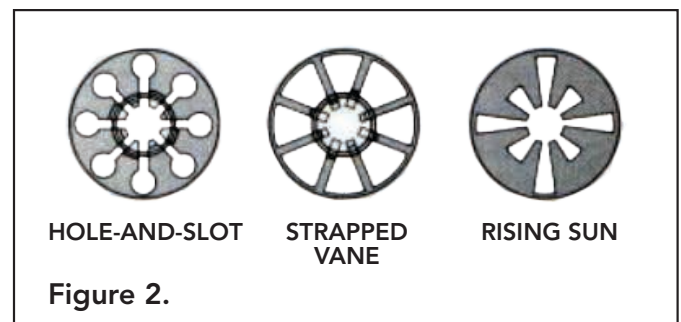

Advantages and disadvantages of each type involve consideration of operating characteristics and construction techniques. The hole-and-slot and vane type normally have every other cavity strapped to each other by a conducting metal strip. The hole-and-slot type and the rising sun type are usually machined by hobbing methods out of solid copper stock. The vane type is generally made up of individual vanes assembled and brazed into a support ring. This requires assembly labor and brazing fixtures.

The anode provides the basic magnetron with its operating frequency. The central area provides C (capacitance) and the outer perimeter contributes L (inductance) to fulfill the relationship

$$F = 1/(2\pi \sqrt{LC})$$

Each anode is cold checked for "Q" - value and frequency. This involves general microwave impedance and resonance measurements techniques.

## Magnetron Theory of Operation: Beacon Magnetrons

### Tuner

The tuner is the device which provides some magnetrons with the ability to vary from the basic frequency determined by the anode. Tuners fall into three basic categories:

- **Capacitive**
- **Inductive**
- **Combination of both**

A fundamental description of each is shown in Figure 3. The capacitive type is so named because in it a tuning member is introduced into the anode cavities affecting the E-field and hence the capacitance of the anode. This type can be constructed of either metal (copper) fingers which are inserted between adjacent anode vanes in the central portion of the anode or a dielectric or metallic ring which is inserted into the anode between its central vane straps.

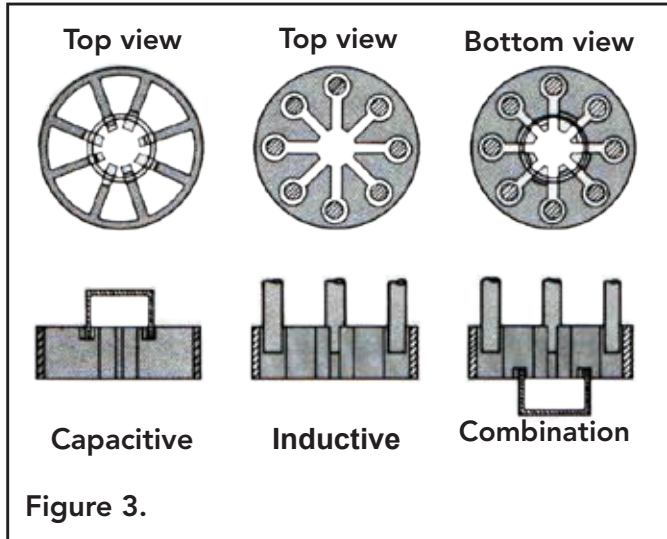

The inductive type tuner is much the same as the capacitive but the tuning member enters the cavities in the back wall region where the H-field and Inductance are affected. The combination of the two is a complicated affair which affects both L and C

and is used where extremely wide tunability is required. The attachment must necessarily involve a bellows or diaphragm arrangement in order to allow for mechanical movement and still contain the necessary vacuum envelope.

Figure 4 shows a simplified capacitive tuner-anode assembly. The magnetron tuner is generally composed of two parts, internal and external. The internal portion described above is that part which is enclosed by the vacuum envelope. The external portion is attached to the internal portion by some mechanical means and provides the drive mechanism to actually move the tuner the required distance to change L and C and therefore change frequency.

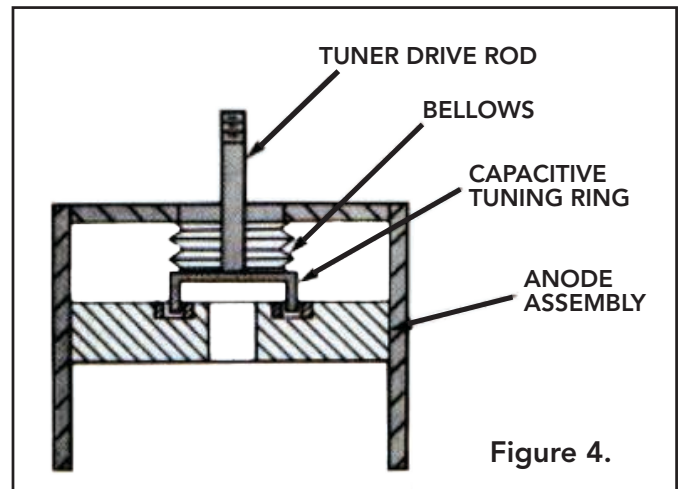

### Cathode

The cathode of a magnetron is the part which makes the magnetron an active device. This provides the electrons through which the mechanism of energy transfer is accomplished. The cathode is usually located in the center of the anode and is made up of a hollow cylinder of emissive material surrounding a heater.

## Magnetron Theory of Operation: Beacon Magnetrons

A cross-section of a simple magnetron cathode is shown in Figure 5. Many types of magnetron cathodes have been developed; each designed for a specific advantage. The fabrication of magnetron cathodes is carried out in very meticulous and precise environments. Each braze and weld must be inspected for completeness in order not to upset the designed heat flow characteristics. Magnetron cathodes are designed to operate at particular temperatures and owing to the phenomenon called "back bombardment" they cannot tolerate wide variations in construction and assembly techniques. As a further check on operating temperature of cathodes used in high reliability magnetrons, the cathode-heater assembly alone is evacuated and operated at a predetermined heater voltages and the cathode temperature checked with an optical pyrometer. This technique reveals any flaw or defect in construction prior to the time the cathode is actually assembled in a magnetron.

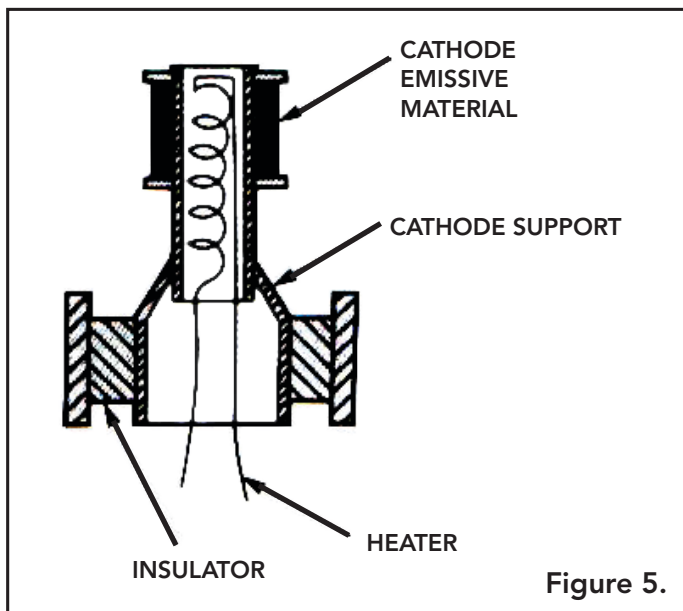

The next step in the magnetron's construction is to attach the cathode to the tuner-anode assembly. This procedure also requires extreme care in the axial line-up and orientation of the cathode and anode. Any eccentricity between anode and cathode will produce variations in magnetron operation and can cause serious internal arcing or malfunction. Figure 6 shows a simplified cathode-tuner-anode assembly.

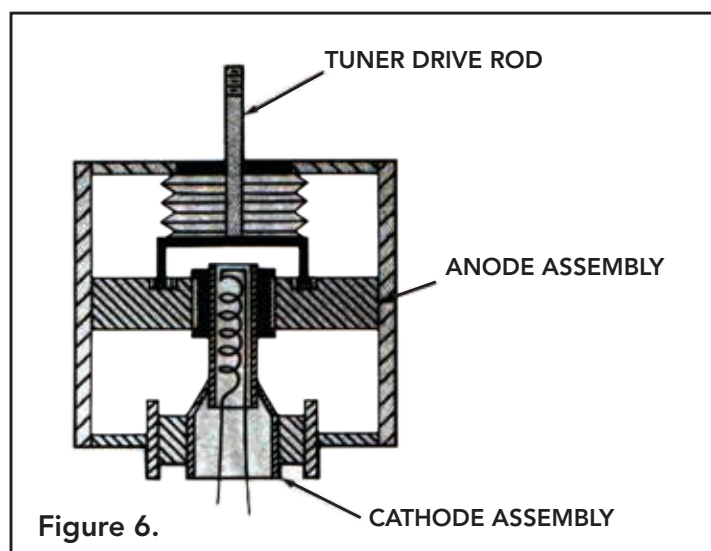

### Output

The output circuit in a magnetron is that portion of the device which provides the coupling to the external load. The RF energy produced in the cavities may be coupled by either a coaxial or waveguide type of output. Figure 7 shows both types. The coaxial design involves either a probe, a loop or a tapped vane coupling to the anode and concentric coaxial line through the vacuum envelope to the output connector. Suitable matching sections must be included along the line to provide for the correct impedance transformations and coupled load which appears at the anode. The center conduction of the coaxial line is insulated and supported along its length by either glass or ceramic beads.

## Magnetron Theory of Operation: Beacon Magnetrons

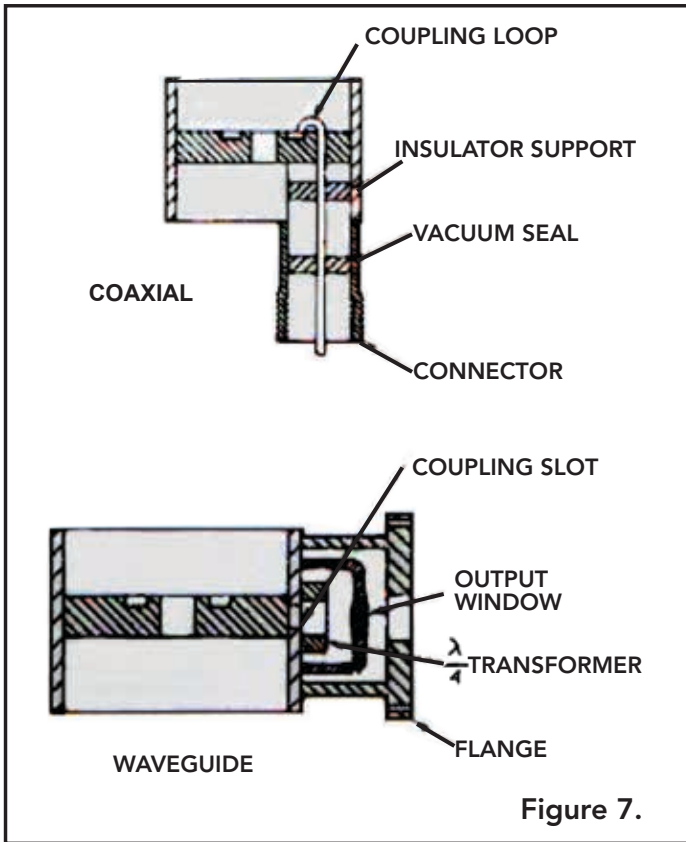

The waveguide type of output is made up of a coupling slot in the back wall of a cavity, a  $\lambda/4$  transformer, a vacuum seal window (either glass or ceramic) and a section of output waveguide. The sizes of the coupling slot and  $\lambda/4$  transformer are determined by frequency, bandwidth and load coupling considerations. The type of vacuum seal window used is determined by the power output and pressurization requirements. Placement of the output window is extremely critical as far as position along the line is concerned, because any high VSWR which may be reflected back from the load that will cause a voltage maximum at the window will cause overheating and subsequent rupture of the vacuum seal.

### Magnetic Circuit

The magnetic circuit associated with the magnetron is necessary to provide the crossed field type of operation which provides for the synchronization of the electron trajectories. The magnetic circuit shown here is composed of an external permanent magnet and associated internal pole pieces. The type and composition of the permanent magnet vary with particular requirements of field strength and stability. Size and weight are also important considerations. The transmission and focusing of the magnetic field from the external permanent magnet to the interaction gap between the anode and cathode is accomplished by the use of high permeability metal pole pieces shaped to focus the field lines as sharply as possible.

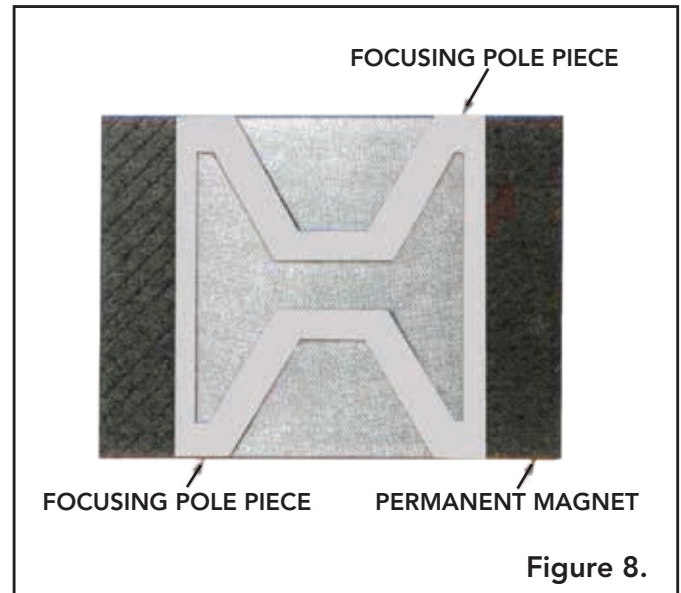

With a history of producing high quality products, we can help you with magnetrons and many other radar products.

**Contact us at [BMDMarketing@cpii.com](mailto:BMDMarketing@cpii.com) or call us at +1 (978) 922-6000.**